

KCET 2020 PHYSICS QUESTION PAPER

1. In a permanent magnet at room temperature
- Domains are all perfectly aligned
 - Magnetic moment of each molecule is zero
 - The individual molecules have non-zero magnetic moment which are all perfectly aligned
 - Domains are partially aligned

2. A rod of length 2 m slides with a speed of 5 ms^{-1} on a rectangular conducting frame as shown in figure. There exists a uniform magnetic field of 0.04 T perpendicular to the plane of the figure. If the resistance of the rod is 3Ω . The current through the rod is

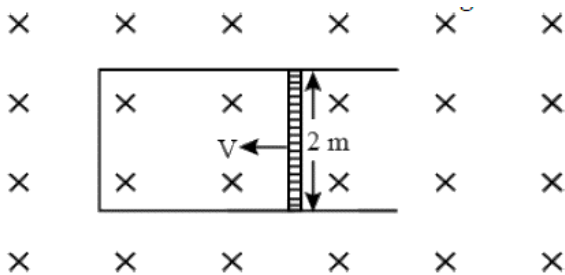

- 1.33 A
 - 75 mA
 - 133 mA
 - 0.75 A
3. The ratio of magnetic field at the centre of a current carrying circular coil to its magnetic moment is 'x'. If the current and the radius both are doubled. The new ratio will become
- $\frac{x}{8}$
 - $2x$
 - $4x$
 - $\frac{x}{4}$
4. In the given circuit the peak voltages across C, L and R are 30 V, 110 V and 60 V respectively. The rms value of the applied voltage is

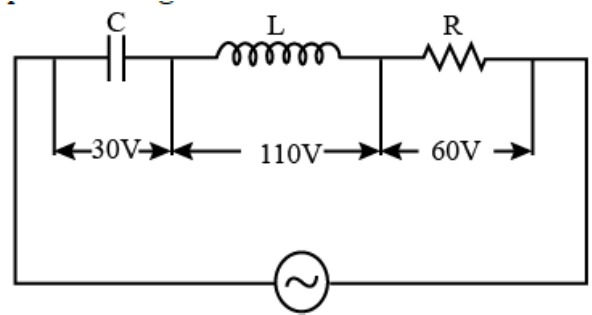

- 141 V
 - 100 V
 - 200 V
 - 70.7 V
5. The power factor of R - L circuit is $\frac{1}{\sqrt{3}}$. If the inductive reactance is 2Ω . The value of resistance is
- $\frac{1}{\sqrt{2}} \Omega$
 - 2Ω
 - $\sqrt{2} \Omega$
 - 0.5Ω
6. In the given circuit, the resonant frequency is

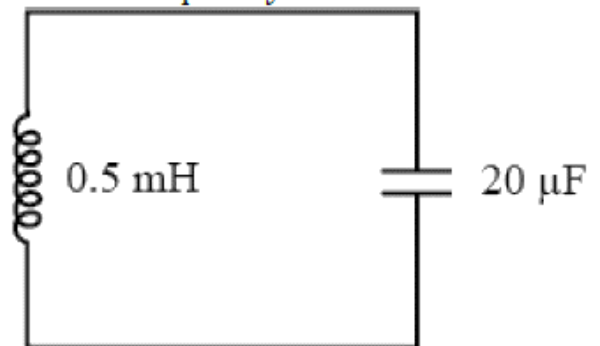

- 15910 Hz
 - 15.92 Hz
 - 159.2 Hz
 - 1592 Hz
7. The current in a coil of inductance 0.2 H changes from 5 A to 2 A in 0.5 sec. The magnitude of the average induced emf in the coil is
- 0.3 V
 - 0.6 V
 - 1.2 V
 - 30 V

8. An object approaches a convergent lens from the left of the lens with a uniform speed $5 \frac{m}{s}$ and stops at the focus, the image
- Moves towards the lens with a non-uniform acceleration
 - Moves away from the lens with uniform speed $5 \frac{m}{s}$
 - Moves away from the lens with uniform acceleration
 - Moves away from the lens with a non-uniform acceleration

9. The refracting angle of a prism is A and refractive index of material of prism is $\cot \frac{A}{2}$. The angle of minimum deviation is
- $180^\circ - 2A$
 - $180^\circ - 3A$
 - $180^\circ + 2A$
 - $90^\circ - 2A$

10. A light beam of intensity $20 \frac{W}{cm^2}$ is incident normally on a perfectly reflecting surface of sides $25 \text{ cm} \times 15 \text{ cm}$. The momentum imparted to the surface by the light per second is
- $1.2 \times 10^{-5} \text{ kg ms}^{-1}$
 - $2 \times 10^{-5} \text{ kg ms}^{-1}$
 - $1 \times 10^{-5} \text{ kg ms}^{-1}$
 - $5 \times 10^{-5} \text{ kg ms}^{-1}$

11. Three polaroid sheets P_1, P_2 and P_3 are kept parallel to each other such, that the angle between pass axes of P_1 and P_2 is 45° and that between P_2 and P_3 is 45° . If Unpolarised beam of light of intensity 128 Wm^{-2} is incident on P_1 . What is the intensity of light coming out of P_3 ?
- 64 Wm^{-2}
 - 128 Wm^{-2}
 - 0
 - 16 Wm^{-2}

12. Two poles are by a distance of 3.14 m. The resolving power of human eye is 1 minute of an arc. The maximum distance from which he can identify the two poles distinctly is

- 376 m
- 10.8 km
- 5.4 km
- 188 m

13. The following figure shows a beam of light converging at point P. When a concave lens of focal length 16 cm is introduced in the path of the beam at a place shown by dotted line such that OP becomes the axis of the lens, the beam converges at a distance x from the lens. The value of x will be equal to

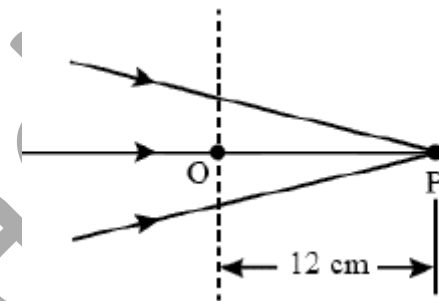

- 48 cm
- 12 cm
- 24 cm
- 36 cm

14. The de - Broglie wavelength associated with electron of hydrogen atom in this ground state is

- 10 \AA
- 0.3 \AA
- 3.3 \AA
- 6.26 \AA

15. The following graph represents the variation of photo current with anode potential for a metal surface. Here I_1, I_2 and I_3 represents intensities and ν_1, ν_2, ν_3 represent frequency for curves 1, 2 and 3 respectively then

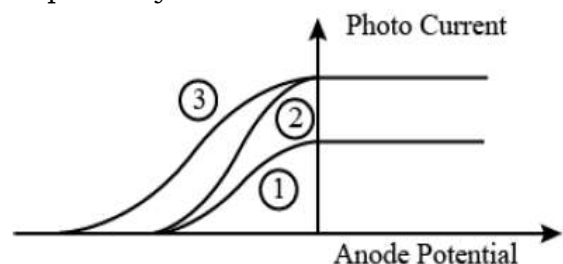

- a) $\gamma_2 = \gamma_3$ and $I_1 = I_3$ b) $\gamma_1 = \gamma_2$ and $I_1 \neq I_2$
 c) $\gamma_1 = \gamma_3$ and $I_1 = I_3$ d) $\gamma_1 = \gamma_2$ and $I_1 = I_2$

16. In Young's Double slit experiment, the distance between the slits and the screen is 1.2 m and the distance between the two slits is 2.4 mm. If a thin transparent mica sheet of thickness $1 \mu\text{m}$ and $R.I. = 1.5$ is introduced between one of the interfering beams, the shift in the position of central bright fringe is
 a) 0.25 mm b) 2 mm
 c) 0.5 mm d) 0.125 mm

17. Angular momentum of an electron in hydrogen atom is $\frac{3h}{2\pi}$ (h is the Planck's constant). The K.E of the electron is
 a) 6.8 eV b) 4.35 eV
 c) 1.51 eV d) 3.4 eV

18. A beam of fast - moving alpha particles were directed towards a thin film of gold. The parts A, B and C of the transmitted and reflected beams corresponding to the incident parts A, B and c of the beam are shown in the adjoining diagram. The number of alpha particles in

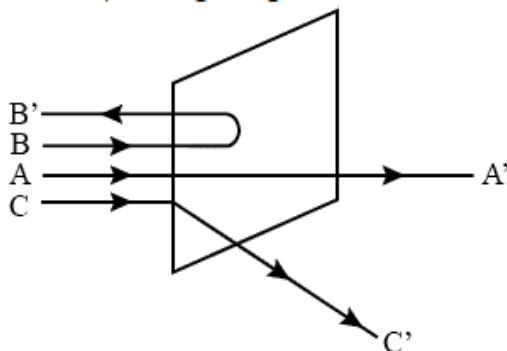

- a) C will be minimum and in B maximum
 b) B will be minimum and in C maximum
 c) A will be maximum and in B minimum
 d) A will be minimum and in B maximum

19. The period of revolution of an electron revolving in n^{th} orbit of H - atom is proportional to

- a) Independent of n b) n^2
 c) $\frac{1}{n}$ d) n^3

20. During a β^- decay

- a) A proton in the nucleus decays emitting an electron.
 b) An atomic electron is ejected
 c) An electron which is already present within the nucleus is ejected
 d) A neutron in the nucleus decays emitting an electron

21. A radio - active element has half - life of 15 years. What is the fraction that will decay in 30 years?

- a) 0.85 b) 0.25
 c) 0.5 d) 0.75

22. Two protons are kept at a separation of 10 nm. Let F_n and F_e be the nuclear force and the electromagnetic force between them

- a) F_e and F_n differ only slightly
 b) $F_e = F_n$
 c) $F_e \gg F_n$
 d) $F_e \ll F_n$

23. In the following circuit what are P and Q:

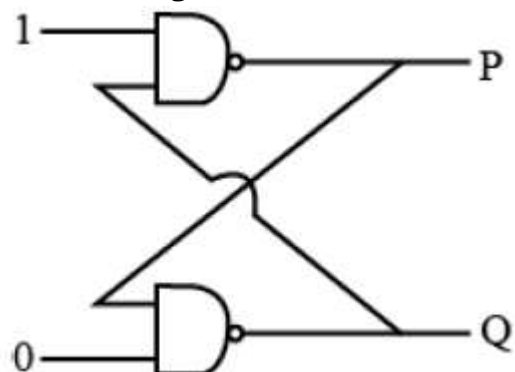

- a) P = 1, Q = 1 b) P = 1, Q = 0
 c) P = 0, Q = 1 d) P = 0, Q = 0

24. A positive hole in a semiconductor is
- An artificially created particle
 - An anti-particle of electron
 - A vacancy created when an electron leaves a covalent bond
 - Absence of free electrons

25. A 220 V A.C supply is connected between points A and B as shown in figure what will be the potential difference V across the capacitor?

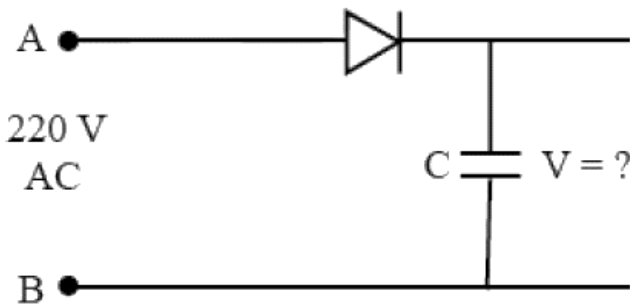

- $220\sqrt{2}$ V
 - 220 V
 - 110 V
 - 0
26. Two long straight parallel wires are a distance $2d$ apart. They carry steady equal currents flowing out of the plane of the paper. The variation of magnetic field B along the line xx' is given by

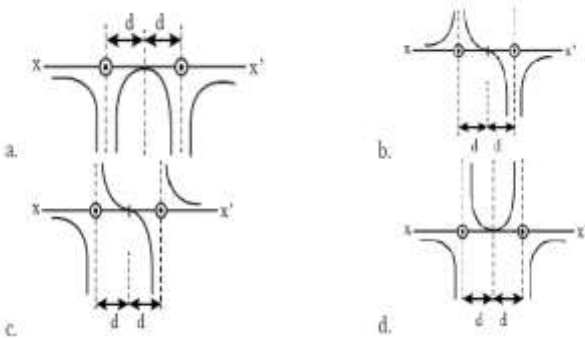

27. At a metro station, a girl walks up a stationary escalator in 20 sec. If she remains stationary on the escalator, then the escalator take her up in 30 sec. The time taken by her to walk up on the moving escalator will be
- 10 sec
 - 25 sec
 - 60 sec
 - 12 sec

28. Rain is falling vertically with a speed of 12 ms^{-1} . A woman rides a bicycles with a speed of 12 ms^{-1} in east to west direction. What is the direction in which she should hold her umbrella?
- 45° towards West
 - 30° towards east
 - 45° towards East
 - 30° towards east

29. A cylindrical wire has mass $(0.3 \pm 0.003) \text{ g}$, radius $(0.5 \pm 0.005) \text{ mm}$ and length $(6 \pm 0.06) \text{ cm}$. The maximum percentage error in the measurement of its density is
- 4
 - 1
 - 2
 - 3

30. A body is initially at rest. It undergoes one-dimensional motion with constant acceleration. The power delivered to it at time 't' is proportional to
- t^2
 - $t^{\frac{1}{2}}$
 - t
 - $t^{\frac{3}{2}}$

31. A thin uniform rectangular plate of mass 2kg is placed in $x-y$ plane as shown in figure. The moment of inertia about x -axis is $I_x = 0.2 \text{ kg m}^2$ and the moment of inertia about y -axis is $I_y = 0.3 \text{ kg m}^2$. The radius of gyration of the plate about the axis passing through O and perpendicular to the plane of the plate is

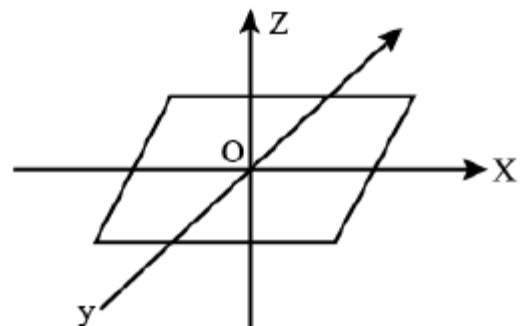

- 31.6 cm
- 50 cm
- 5 cm
- 38.7 cm

32. One end of a string of length 'l' is connected to a particle of mass 'm' and the other to a small peg on a smooth horizontal table. If the particle move in a circle with speed 'v', the net force on the particle (directed towards the centre) is: (T is the tension in the string)

- a) 0
 b) T
 c) $T = \frac{mv^2}{l}$
 d) $T + \frac{mv^2}{l}$

33. Young's modulus of a perfect rigid body is

- a) Between zero and unity
 b) Zero
 c) Unity
 d) Infinity

34. A wheel starting from rest gains an angular velocity of 10 rad/s after uniformly accelerated for 5 sec. The total angle through which it has turned is

- a) 50π rad about a vertical axis
 b) 25 rad
 c) 100 rad
 d) 25π rad

35. Iceberg floats in water with part of it submerged. What is the fraction of the volume of iceberg submerged if the density of ice is $\rho_i = 0.917 \text{ g cm}^{-3}$?

- a) 0
 b) 0.917
 c) 1
 d) 0.458

36. The value of acceleration due to gravity at a height of 10 km from the surface of earth is x. At what depth inside the earth is the value of the acceleration due to gravity has the same value x?

- a) 15 km
 b) 5 km
 c) 20 km
 d) 10 km

37. In an adiabatic expansion of an ideal gas the product of pressure and volume

- a) At first increases and then decreases
 b) Decreases
 c) Increases
 d) Remains constant

38. A certain amount of heat energy is supplied to a monoatomic ideal gas which expands at constant pressure. What fraction of the heat energy is converted into work?

- a) $\frac{5}{7}$
 b) 1
 c) $\frac{2}{3}$
 d) $\frac{2}{5}$

39. A sphere, a cube and a thin circular plate all of same material and same mass initially heated to same high temperature are allowed to cool down under similar conditions. Then the

- a) Cube will cool the fastest and plate the slowest
 b) Plate will cool the fastest and cube the slowest
 c) Sphere will cool the fastest and cube the slowest
 d) Plate will cool the fastest and sphere the slowest

40. A train whistling at constant frequency 'n' is moving towards a station at a constant speed V. The train goes past a stationary observer on the station. The frequency 'n' of the sound as heard by the observer is plotted as a function of time 't'. Identify the correct curve.

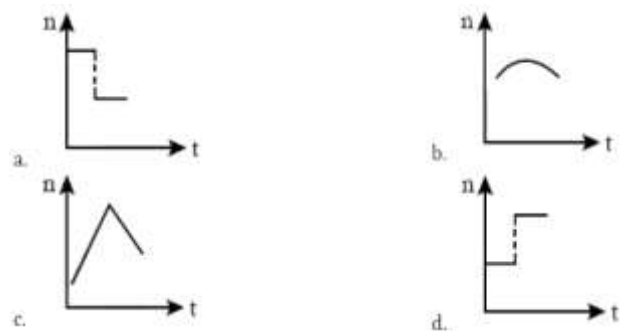

41. An infinitely long thin straight wire has uniform charge density of $\frac{1}{4} \times 10^{-2} \text{ cm}^{-1}$.

What is the magnitude of electric field at a distance 20 cm from the axis of the wire?

- a) $9 \times 10^8 \text{ NC}^{-1}$
 b) $1.12 \times 10^8 \text{ NC}^{-1}$
 c) $4.5 \times 10^8 \text{ NC}^{-1}$
 d) $2.25 \times 10^8 \text{ NC}^{-1}$

42. A tray of mass 12 kg is supported by two identical springs as shown in figure. When the tray is pressed down slightly and then released SHM with a time period of 1.5 s. The spring constant of each spring is

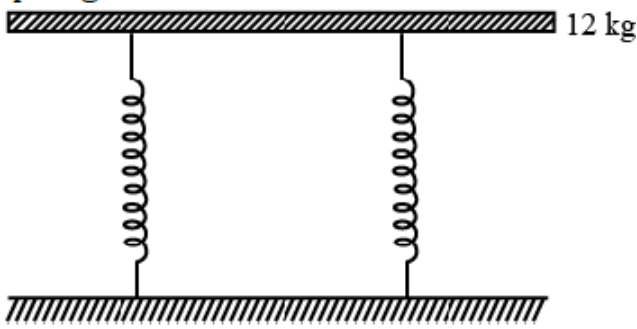

- a) ∞ b) 50 Nm^{-1}
c) 0 d) 105 Nm^{-1}

43. The electric field lines on the left have twice the separation on those on the right as shown in figure. If the magnitude of the field at A is 40 V m^{-1} , what is the force on $20 \text{ } \mu\text{C}$ charge kept at B?



- a) $1 \times 10^{-4} \text{ V m}^{-1}$ b) $4 \times 10^{-4} \text{ V m}^{-1}$
c) $8 \times 10^{-4} \text{ V m}^{-1}$ d) $16 \times 10^{-4} \text{ V m}^{-1}$

44. A point charge 'q' is placed at the corner of a cube side 'a' as shown in the figure. What is the electric flux through the face ABCD?

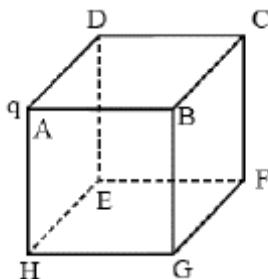

- a) $\frac{q}{72\epsilon_0}$ b) 0
c) $\frac{q}{24\epsilon_0}$ d) $\frac{q}{6\epsilon_0}$

45. The difference between equivalent capacitances of two identical capacitors connected in parallel to that in series is $6 \text{ } \mu\text{F}$. The value of capacitance of each capacitor is

- a) $6 \text{ } \mu\text{F}$ b) $2 \text{ } \mu\text{F}$
c) $3 \text{ } \mu\text{F}$ d) $4 \text{ } \mu\text{F}$

46. Figure shows three points A, B and C in a region of uniform electric field \vec{E} . The line AB is perpendicular and BC is parallel to the field lines. Then which of the following holds good? (V_A, V_B and V_C represent the electric potential at points A, B and C respectively)

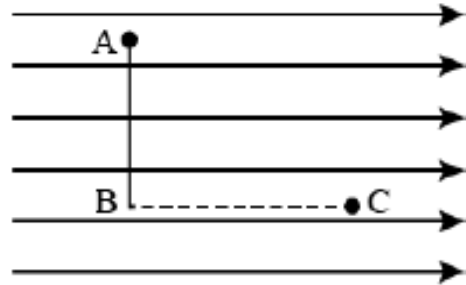

- a) $V_A > V_B = V_C$ b) $V_A = V_B = V_C$
c) $V_A = V_B > V_C$ d) $V_A = V_B < V_C$

47. A dipole of dipole moment 'p' and moment of inertia I is placed in a uniform electric field \vec{E} . If it is displaced slightly from its equilibrium position, the period of oscillation of dipole is

- a) $\pi \sqrt{\frac{i}{pE}}$ b) $\sqrt{\frac{PE}{I}}$
c) $2\pi \sqrt{\frac{I}{pE}}$ d) $\frac{1}{2\pi} \sqrt{\frac{PE}{I}}$

48. A hot filament liberates an electron with zero initial velocity. The anode potential is 1200 V. The speed of the electron when it shares the anode is

- a) $2.5 \times 10^8 \text{ ms}^{-1}$ b) $1.5 \times 10^5 \text{ ms}^{-1}$
c) $2.5 \times 10^6 \text{ ms}^{-1}$ d) $2.1 \times 10^7 \text{ ms}^{-1}$

49. A metal rod of length 10 cm and a rectangular cross-section of $1\text{ cm} \times \frac{1}{2}\text{ cm}$ is connected to a battery across opposite faces. The resistance will be

- Same irrespective of the three faces
- Maximum when the battery is connected across $1\text{ cm} \times \frac{1}{2}\text{ cm}$ faces
- Maximum when the battery is connected across $10\text{ cm} \times \frac{1}{2}\text{ cm}$ faces
- Maximum when the battery is connected across $10\text{ cm} \times 1\text{ cm}$ faces

50. A car has a fresh storage battery of e.m.f 12 V and internal resistance $2 \times 10^{-2}\Omega$. If the starter motor draws a current of 80 A. Then the terminal voltage when the starter is on is

- 9.3 V
- 12 V
- 8.4 V
- 10.4 V

51. When a soap bubble is charged?

- Its radius may increase or decrease
- Its radius increases
- Its radius decreases
- The radius remains the same

52. The colour code for a carbon resistor of resistance $0.25\text{ k}\Omega \pm 10\%$ is

- Red, Green, Silver
- Red, Grey, Brown, Silver
- Red, Green, Brown, Silver
- Red, Grey, Silver, Silver

53. Each resistance in the given cubical network has resistance of 1Ω and equivalent resistance between A and B is

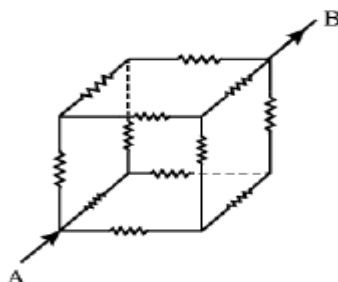

- $\frac{12}{5}\Omega$
- $\frac{5}{6}\Omega$
- $\frac{6}{5}\Omega$
- $\frac{5}{12}\Omega$

54. A potentiometer has a uniform wire of length 5 m. A battery of emf 10V and negligible internal resistance is connected between its ends. A secondary cell connected to the circuit gives balancing length at 200 cm. The emf of the secondary cell is

- 8 V
- 4 V
- 6 V
- 2 V

55. In the given figure the magnetic field at 'O'

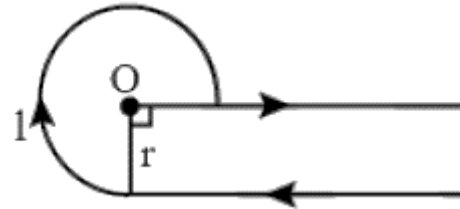

- $\frac{3}{8} \frac{\mu_0 I}{r} - \frac{\mu_0 I}{4\pi r}$
- $\frac{3}{4} \frac{\mu_0 I}{r} + \frac{\mu_0 I}{4\pi r}$
- $\frac{3}{10} \frac{\mu_0 I}{r} - \frac{\mu_0 I}{4\pi r}$
- $\frac{3}{8} \frac{\mu_0 I}{r} + \frac{\mu_0 I}{4\pi r}$

56. The magnetic field at the origin due to a current element $i\vec{dl}$ placed at a point with vector position \vec{r} is

- $\frac{\mu_0 i}{4\pi} \frac{\vec{r} \times \vec{dl}}{r^2}$
- $\frac{\mu_0 i}{4\pi} \frac{\vec{dl} \times \vec{r}}{r^3}$
- $\frac{\mu_0 i}{4\pi} \frac{\vec{r} \times \vec{dl}}{r^3}$
- $\frac{\mu_0 i}{4\pi} \frac{\vec{dl} \times \vec{r}}{r^2}$

57. $I-V$ Characteristic of a copper wire of length L and area of cross-section A is shown in figure. The slope of the curve becomes

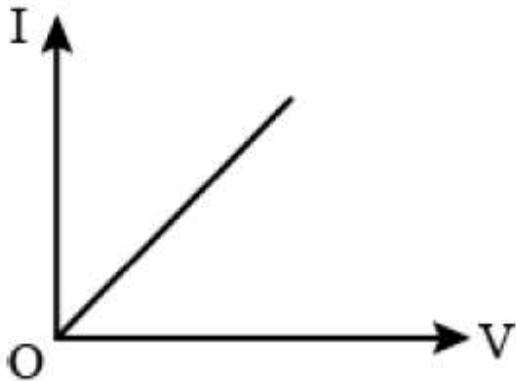

- Less if the length of the wire is increased
- More if experiment is performed at higher temperature
- More if a wire of steel of same dimension is used
- Less if the area of the wire is increased

58. A cyclotron is used to accelerate protons

$\left(\frac{1}{1}H\right)$, Deuterons $\left(\frac{2}{1}H\right)$ and α -particles $\left(\frac{4}{2}He\right)$. While existing under similar

conditions, the minimum K.E is gained by

- Same for all
- α -particle
- Proton
- Deuteron

59. A paramagnetic sample shows a net magnetization of $8Am^{-1}$ when placed in an external magnetic field of 0.6 T at a temperature of 4 K. when the same sample is placed in an external magnetic field of 0.2 T at a temperature of 16 K. The magnetization will be

- $2.4Am^{-1}$
- $\frac{32}{3}Am^{-1}$
- $\frac{2}{3}Am^{-1}$
- $6Am^{-1}$

60. A long cylindrical wire of radius R carries a uniform current I flowing through it. The variation of magnetic field with distance ' r ' from the axis of the wire is shown by

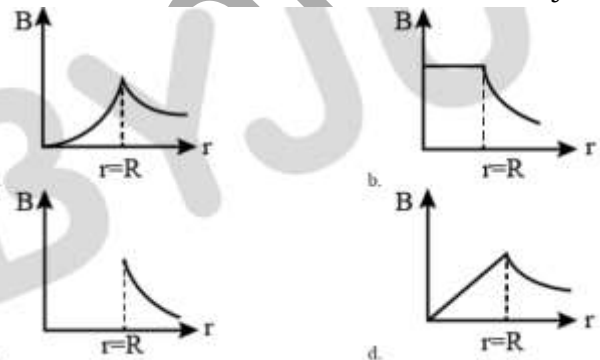

ANSWER KEYS

1. (a)	2. (c)	3. (a)	4. (d)	5. (c)	6. (d)	7. (c)	8. (d)	9. (a)	10. (d)
11. (d)	12. (b)	13. (a)	14. (c)	15. (b)	16. (a)	17. (c)	18. (c)	19. (d)	20. (d)
21. (d)	22. (c)	23. (c)	24. (c)	25. (a)	26. (c)	27. (d)	28. (a)	29. (a)	30. (c)
31. (b)	32. (b)	33. (b)	34. (b)	35. (b)	36. (c)	37. (b)	38. (d)	39. (d)	40. (a)
41. (d)	42. (b)	43. (b)	44. (b)	45. (d)	46. (c)	47. (c)	48. (d)	49. (b)	50. (d)
51. (b)	52. (b)	53. (b)	54. (b)	55. (d)	56. (b)	57. (a)	58. (d)	59. (c)	60. (a)